

SRRTEP Committee: Western AEP Supplemental Projects

July 17, 2020

Needs

Stakeholders must submit any comments within 10 days of this meeting in order to provide time necessary to consider these comments prior to the next phase of the M-3 process

Need Number: AEP-2020-AP036

Process Stage: Needs Meeting 7/17/2020

Supplemental Project Driver: Customer Service

Specific Assumptions Reference: AEP Connection Requirements for the AEP Transmission System (AEP Assumptions Slide 7)

Problem Statement:

- Distribution requested a new station (Winston Avenue) located just south of the Hancock-Walnut Avenue 69 kV circuit to serve load currently fed from Walnut Avenue Station, which is located in the flood way of the Roanoke River as determined by FEMA and the Army Corps of Engineers. There have been several instances in the last three years where prolonged periods of rain have resulted in water levels that reached the bottom of the breaker control cabinets in the station.
- Medical and Health Facilities load continues to grow in the area served by Walnut Avenue Station. The main feed for Roanoke Memorial Hospital (RMH) is the Walnut Avenue/South Roanoke 12 kV feeder. RMH has plans to construct a new 15 story (2 MVA) expansion at nearby Crystal Springs along with a renovation/relocation of their existing Cancer Center by April 2024. The load on the South Roanoke 12 kV feeder is projected to reach 8.9 MVA, or 69% of its 12.9 MVA capability by summer 2024. This load is primarily RMH and while the concern is not necessarily related to a projected overload, it is about having Roanoke’s largest hospital served by a main feed in the Roanoke River Floodway and its alternate feed (Wasena/Wiley 12kV) in the Roanoke River Floodplain.
- The Walnut Avenue/Maher Ave 12 kV feeder has seen and will continue to see Medical and Health Facilities growth. Recent additions have been the Virginia Tech School of Medicine, Carilion Biomedical center for which the first of three planned expansions was announced for 6/2020. The load on the Maher Avenue 12 kV feeder is projected to reach 9.1 MVA, or 80% of its 11.4 MVA capability by summer 2024. While the concern is not necessarily related to a projected overload, cold load pickup is a concern following an outage when trying to restore power on a 12 kV feeder when its load exceeds 9.0 MVA.

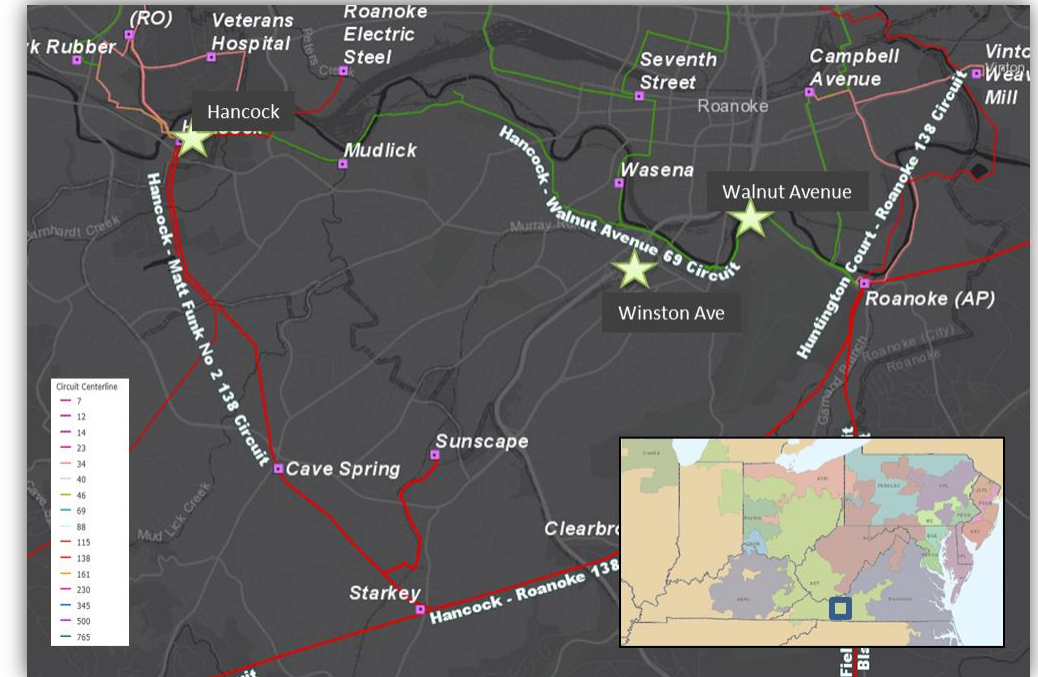

AEP Transmission Zone M-3 Process Smyth County, VA

Need Number: AEP-2020-AP037

Process Stage: Need Meeting 7/17/2020

Supplemental Project Driver:

Equipment Material/Condition/Performance/Risk

Specific Assumption Reference:

AEP Guidelines for Transmission Owner Identified Needs (AEP Assumptions Slide 8)

Problem Statement:

Station Name: Saltville

Circuit Breakers A, B, C, L & V (138 KV) Concerns:

- All of these breakers are HVB145-40000. These breakers are of either 1996 (A & B) or 2001 (C, L, & V) vintage.
- These CBs require maintenance beyond the typical SF6 model type because of air trip mechanisms. The entire air system must be rebuilt whenever maintenance is performed resulting in significant costs.
- All of these breakers have exceeded the manufacturer's designed number of full fault operations – Breakers A, B, C, L, V have experienced 51, 75, 12, 22, 70 fault operations, respectively —exceeding manufacturer's recommended number of 10.

Circuit Breakers J (69 KV) Concerns:

- Circuit breaker J is 53 years old, CF-48-69-2500 type, oil filled breaker – which requires frequent maintenance. Oil spills are common and can result in significant environmental mitigation costs.
- This breaker has experienced 34 fault operations — exceeding manufacturer's recommended number of 10.
- There is no support for the CF family of circuit breakers and spare parts are obsolete, impossible to obtain.

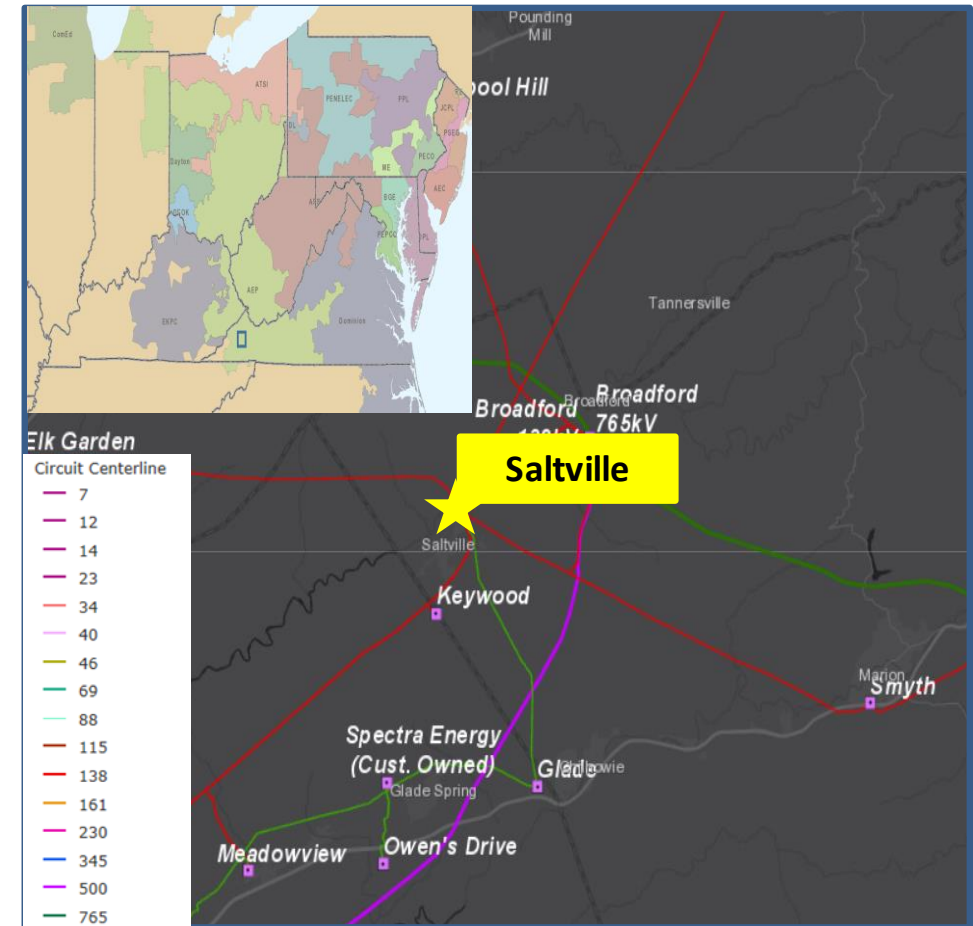

Saltville Station (continued)

Transformer Bank 1 (138/69-34.5 KV) Concerns:

- The 138/69-34.5 KV Transformer Bank is 53 years old with no oil containment
- This unit shows elevated levels of Carbon Dioxide and Ethane, which are currently at IEEE Level 3 and 4, respectively. These levels indicate excessive decomposition of the paper insulating materials.
- The presence of Carbon Dioxide and Ethane indicates decomposition of the paper insulation that impairs the unit to withstand future short circuit or through fault events due to the state of the paper insulation.
- The low side surge arresters (on 69KV) are obsolete and in need of replacement.

Other station concerns:

- The station yard is tiered with stairs to access the different levels which creates a washout risk.
- Power transformers XF#1, XF#2, and XF#5 are connected directly to 138kV bus through MOABs — which renders Saltville bus#1 and bus#2 to a transformer fault. Moreover, malfunction record indicated that the MOAB X1 would not open during trip testing due to the plunger sticking on the contactor. Also, MOAB X2 is on cap and pin insulators.
- Perimeter fence is not standard height and damaged.
- Concrete cable trench along retaining wall is damaged.
- Several foundations throughout station are degraded.
- Lower elevation levels in the station yard are in the 100-year flood plain of the nearby New River.
- Asbestos and lead paint in both of the control buildings.

Relay concerns:

- Currently, 79 of the 95 relays are in need of replacement.
- There are 68 of the electromechanical, 6 static type and 5 legacy microprocessor relays — which have significant limitations with regards to fault data collection and retention.

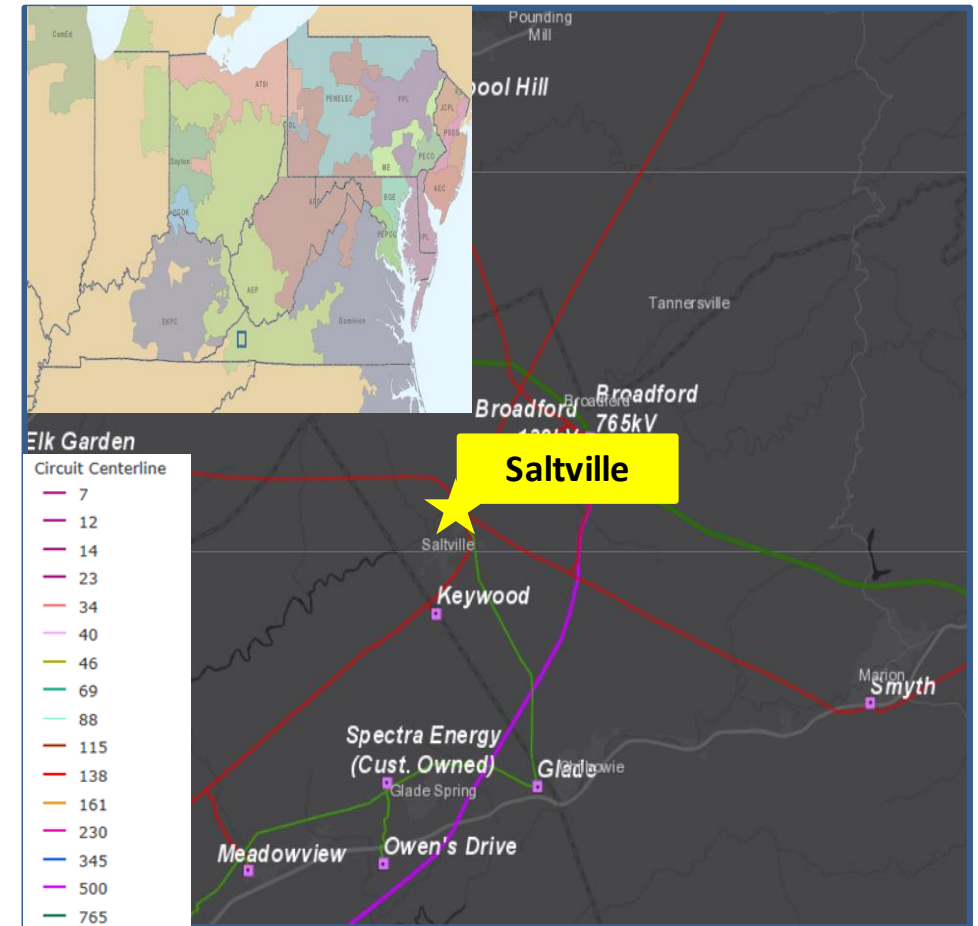

AEP Transmission Zone: Supplemental Rocky Mount, VA Area

Need Number: AEP-2020-AP038

Process Stage: Needs Meeting 07/17/2020

Supplemental Project Driver: Equipment Material/Condition/Performance/Risk

Specific Assumptions Reference: AEP Guidelines for Transmission Owner Identified Needs (AEP Assumptions Slide 8)

Problem Statement:

• **Grassy Hill Loop and Tank Hill Tap 138 kV Line Asset (1.3 mi.)**

- The single circuit wood pole structures that make up 0.95 miles of the 1.3 mile long Grassy Hill Loop and Tank Hill Tap 138 kV Line Asset are the focus of the concern.
- Recent field assessments have identified severe Woodpecker holes and cracking damage, accounting for 67% of the 12 single pole structures on the radial line.
 - Weather cracks range in size from 2 to 7 feet in length, with many poles having multiple.
 - Woodpecker holes range in size from 1 to 5 inches in diameter and the poles have 10 to 30 of them.
 - A pole appears to be hollow on the inside.
 - A pole has mold on the upper portion, that is 10 feet in length.
- The radial line feeds sensitive industrial customers in the Rocky Mount, VA area. These customers operate 24 hours a day and do not take outages. The Tank Hill station that is fed from the Fieldale – Roanoke line is the only station that can handle the industrial load.
- From 2015, there have been 6 momentary and 2 permanent outages on the associated Fieldale - Roanoke circuit.

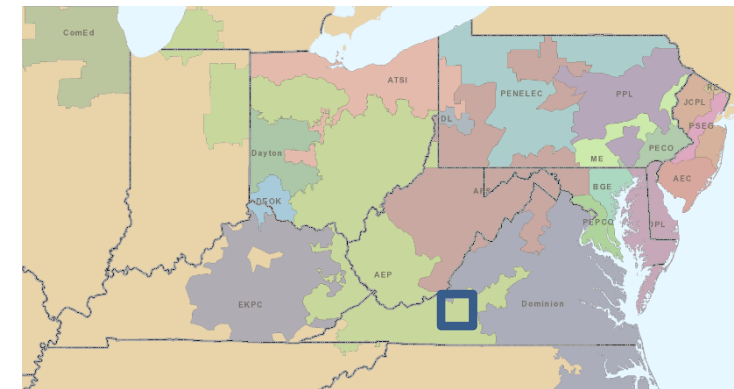
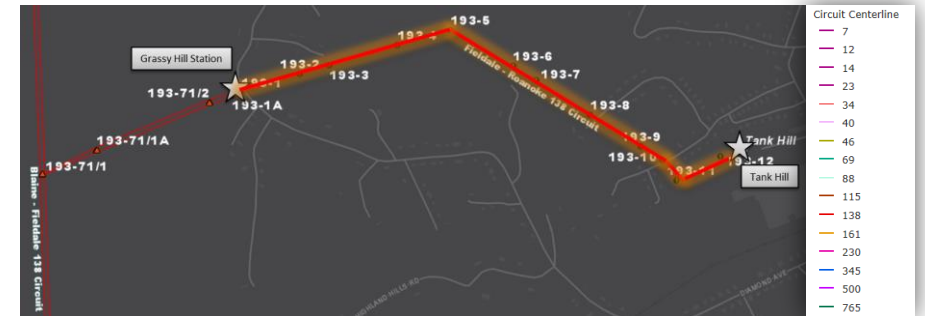

AEP Transmission Zone M-3 Process Malta, Ohio

Need Number: AEP-2020-OH028

Process Stage: Need Meeting 7/17/2020

Supplemental Project Driver: Equipment Condition/Performance/Risk

Specific Assumption Reference:

AEP Guidelines for Transmission Owner Identified Needs (AEP Assumptions Slide 8)

Problem Statement:

West Malta 69kV

Circuit Breaker "A" 1965

- Interrupting Medium: Oil
- Additional Information:
 - Interrupting Capability: 21 kA
 - Oil breaker maintenance has become more difficult due to the oil handling required to maintain them. Oil spills are frequent with breaker failures and routine maintenance and can become an environmental hazard. Spare parts for these units are not available due to their obsolescence.

Additional Information:

- MOAB X has a retrofitted motor mechanism installed that prohibits the switch from opening correctly.
- Overlapping zone of protection exist at the station between a 69 kV line, the bus, and the 69/12 kV transformer which can result in relay coordination issues.
- 23 of the 25 relays at the station are of the electromechanical type and 2 of the static type all of which have significant limitations with regards to fault data collection and retention. In addition, these no longer have vendor support and spare parts are unavailable.

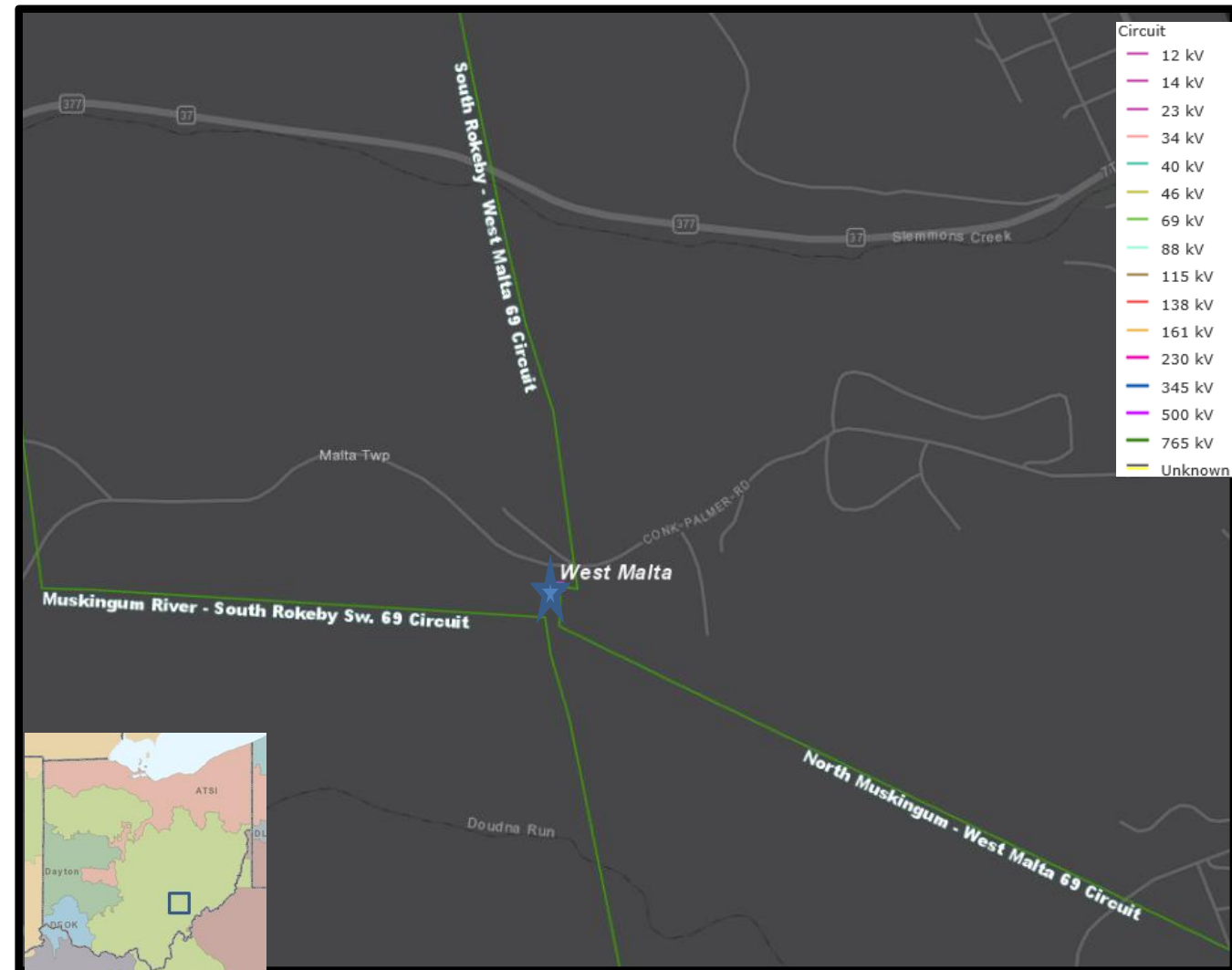

AEP Transmission Zone M-3 Process
Lima Ohio

Need Number: AEP-2020-OH035

Process Stage: Need Meeting 07/17/2020

Project Driver:
Customer Service

Specific Assumption Reference:
AEP Connection Requirements for the AEP Transmission System
(AEP Assumptions Slide 7)

Problem Statement:
A new customer request has been made to provide service to a
1.7 MW load along the Shawnee Road – Sterling 34.5kV circuit.

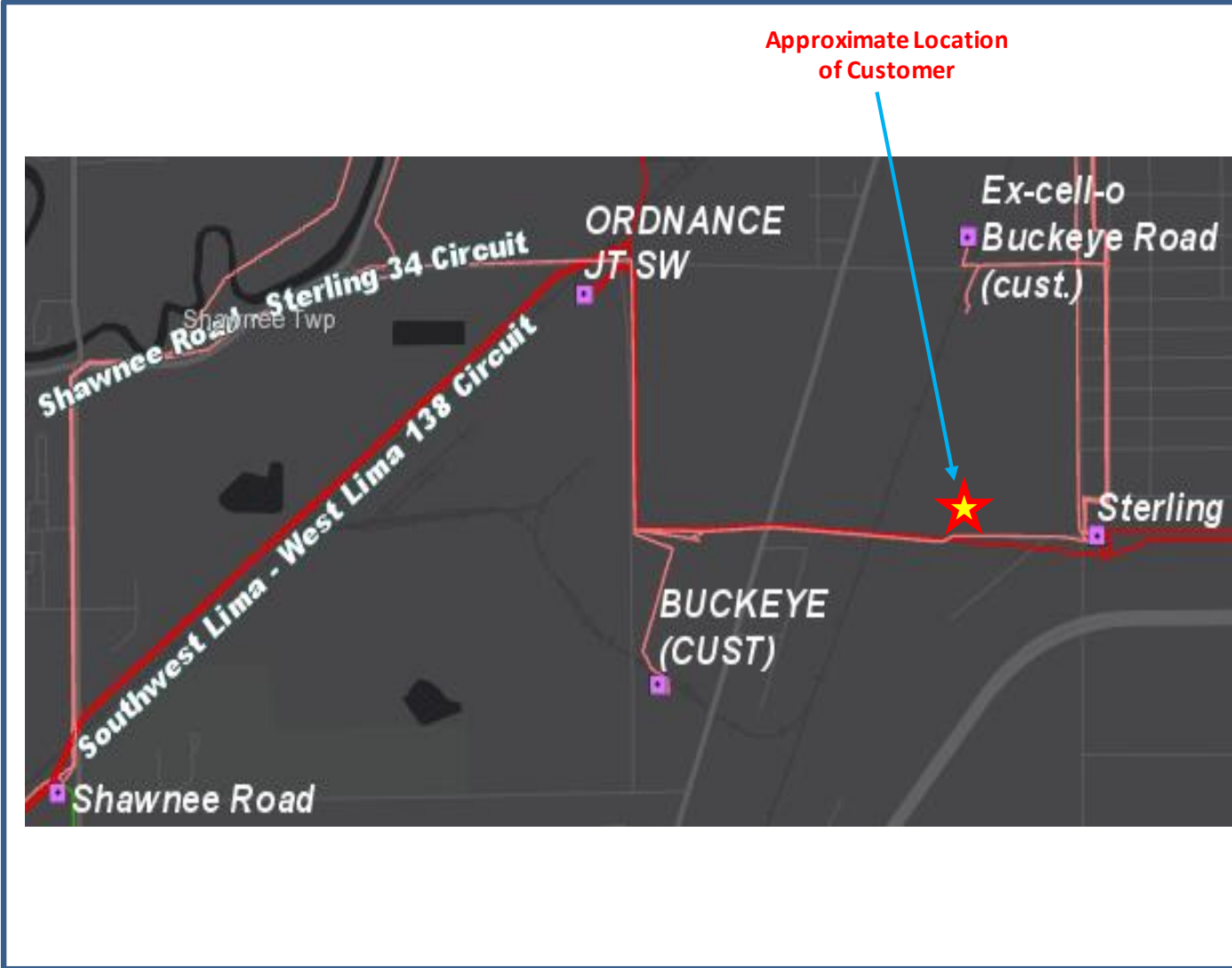

Solutions

Stakeholders must submit any comments within 10 days of this meeting in order to provide time necessary to consider these comments prior to the next phase of the M-3 process

AEP Transmission Zone M-3 Process Salerno 138kV

Need Number: AEP-2020-OH002

Process Stage: Solutions Meeting 07/17/2020

Previously Presented:

Need Meeting 01/17/2020

Supplemental Project Driver:

Customer Service

Specific Assumption Reference:

AEP Guidelines for Transmission Owner Identified Needs (AEP Assumptions slide 7)

Problem Statement:

- AEP Ohio is requesting a new 138kV delivery point on the Academia – North Lexington 138 kV circuit by May 2023. Anticipated load is approximately 15 MVA.

Model: 2024 RTEP

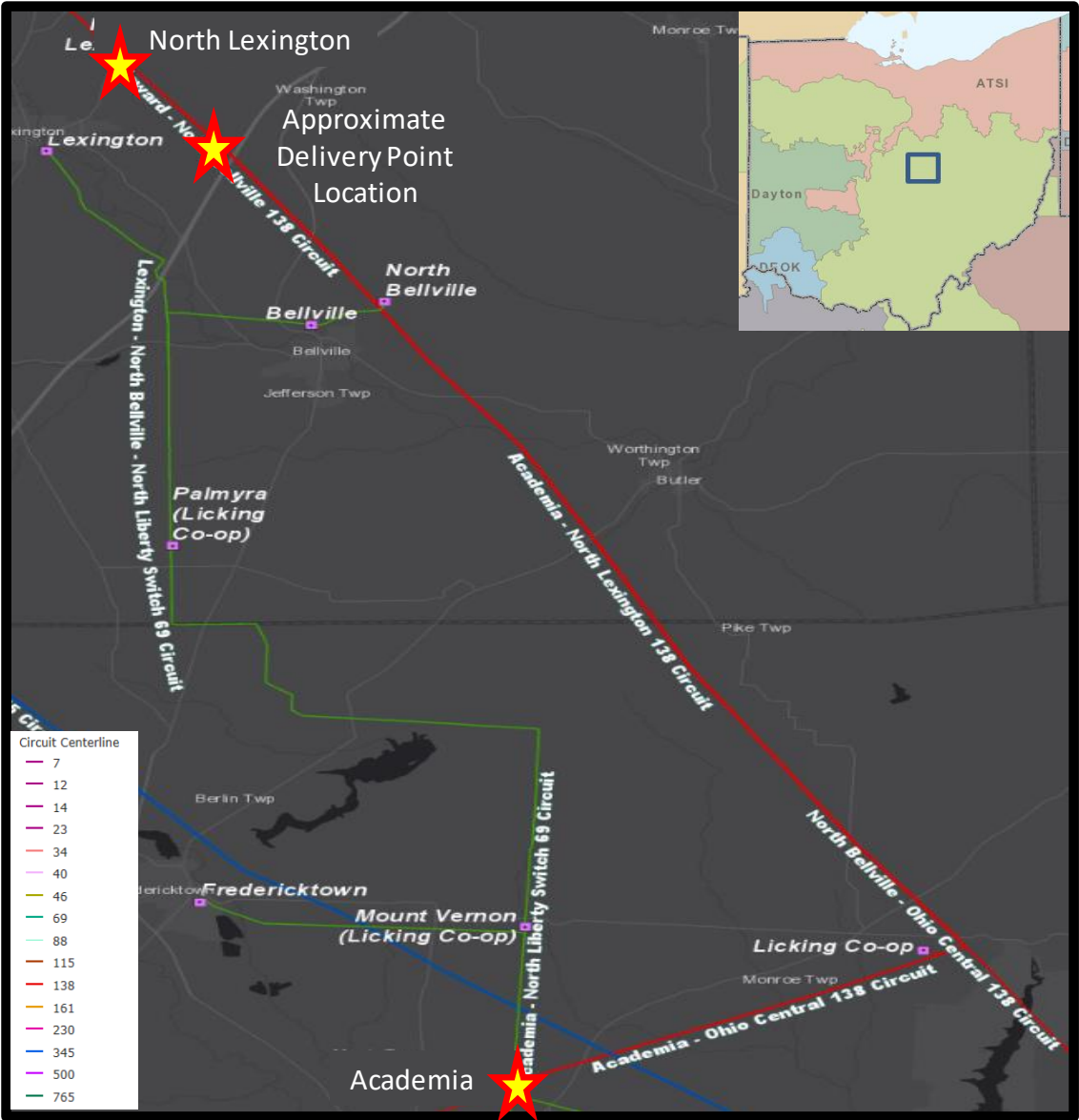

AEP Transmission Zone M-3 Process Salerno 138kV

Need Number: AEP-2020-OH002

Process Stage: Solutions Meeting 07/17/2020

Proposed Solution:

- Install a greenfield 138kV in-out station (“Salerno”) with one auto sectionalizing switch on the line exit towards Academia one non-auto sectionalizing switch on the line exit towards North Lexington. **Estimated Cost: \$1.4M**
- Install two 138kV single circuit lines, approximately 0.1 miles each, to tie the greenfield Salerno station to the Academia-North Lexington 138kV circuit with 795 ACSR. **Estimated Cost: \$0.6M**
- Remove/Relocate approximately 0.1 mile of line on the Philo – Howard Line asset. Install ~1.7 miles of fiber to provide SCADA connectivity to Salerno. **Estimated Cost: \$0.3M**

Total Estimated Transmission Cost: \$2.3M

Alternatives Considered:

Considering the location of the customer request, no viable cost-effective transmission alternative was identified. AEP Ohio already owns land in this area for the delivery point.

Projected In-Service: 05/16/2022

Project Status: Scoping

Model: 2024 RTEP

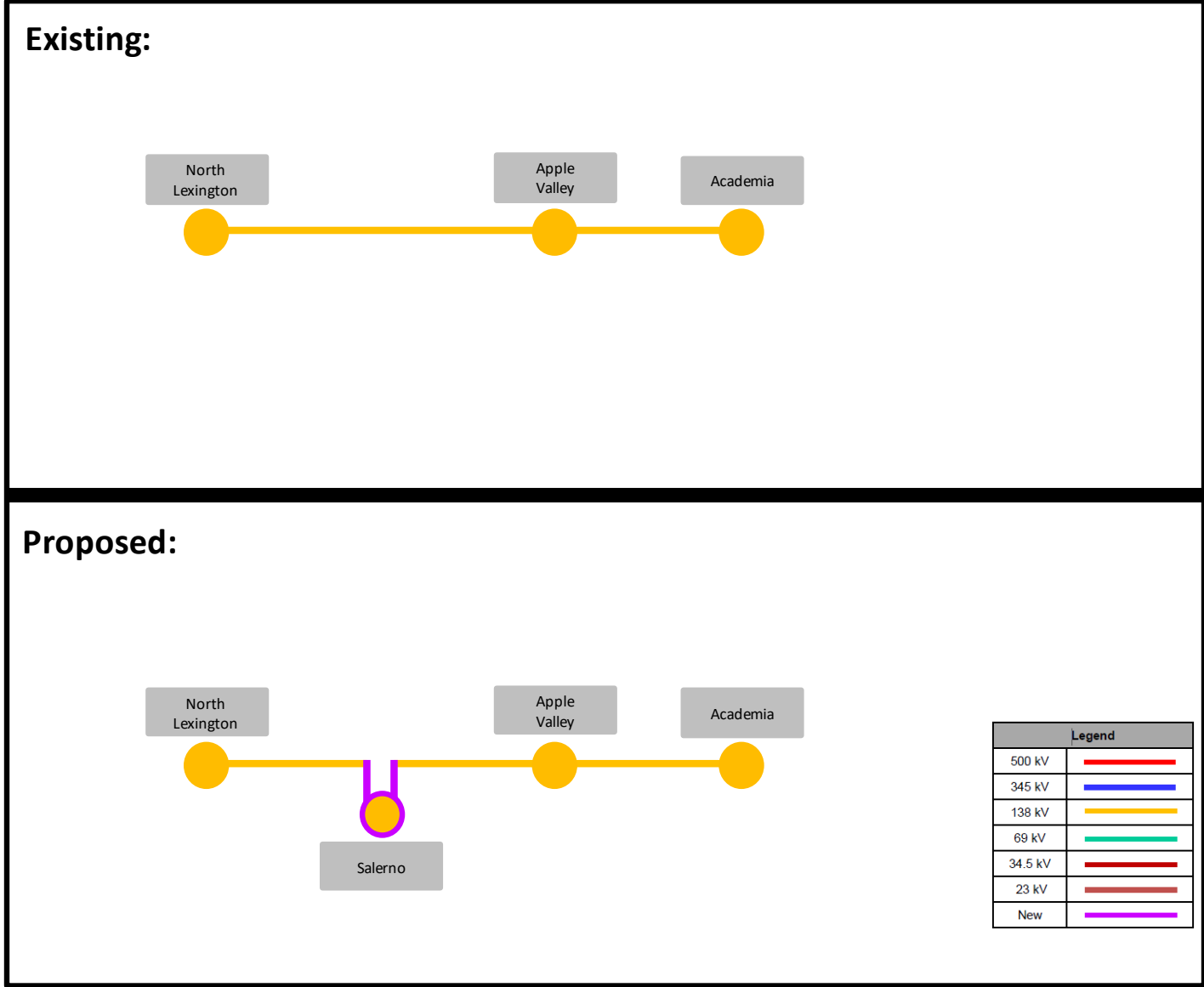

AEP Transmission Zone: Supplemental Colony Bay – Melita 69kV Line Rebuild

Need Number: AEP-2020-IM015

Process Stage: Solutions Meeting 7/17/2020

Previously Presenter: Needs Meeting 4/20/2020

Supplemental Project Driver: Equipment

Material/Condition/Performance/Risk

Specific Assumptions Reference: AEP Guidelines for Transmission Owner Identified Needs (AEP Assumptions Slide 8)

Problem Statement:

Colony Bay – Melita 69kV (5.8 miles)

- The Colony Bay – Melita circuit has ~5.8 miles of primarily 1960 wood pole structures
- This section has 34 open conditions across 26 unique poles (~17% of line). These conditions include, but aren't limited to Stolen/broken ground leads, broken insulators, damaged and rotting poles.
- An additional 23 poles on this section (~15%) were found to be decayed to the point of failure. These poles had steel reinforcers installed to allow them to last until a more permanent fix was available.
- The 2014-2019 5 year period this line was subject to 3 momentary outages and 3 permanent outages.

Hadley 69kV station

- Station has a bus tie switch that breakers the bus differential. AEP has been addressing these as we have the opportunity

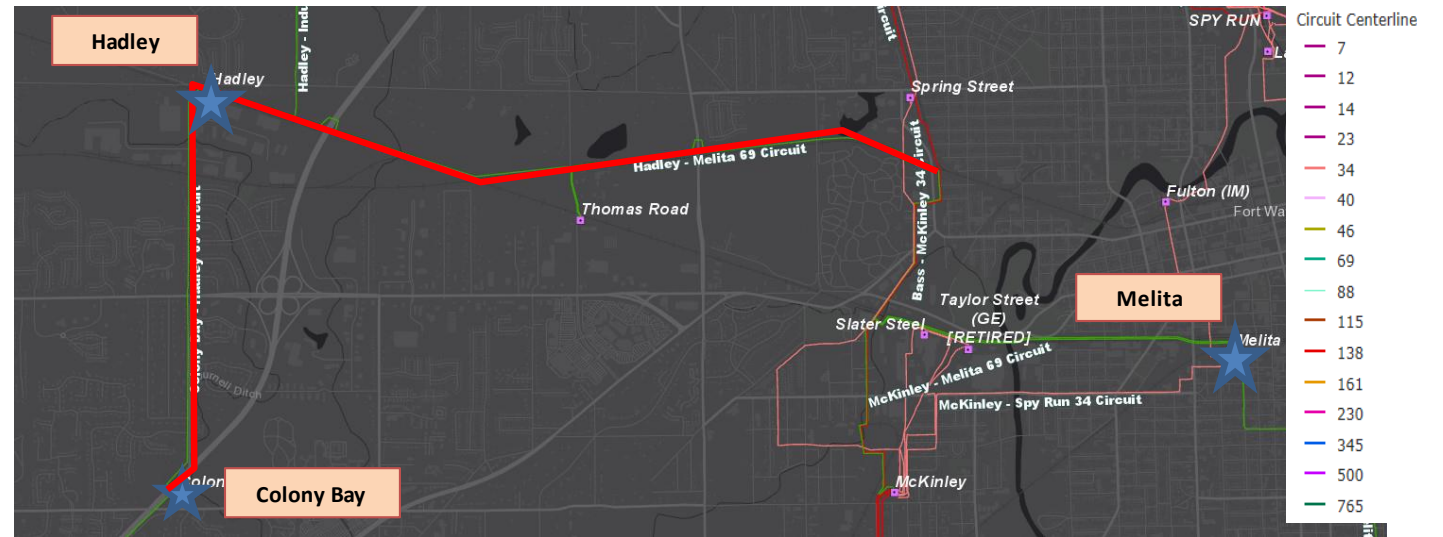

AEP Transmission Zone: Supplemental Colony Bay – Melita 69kV Line Rebuild

Need Number: AEP-2020-IM015
Process Stage: Solutions Meeting 7/17/2020
Proposed Solution:

Rebuild the ~5.8 mile 69kV line from Colony Bay to the McKinley– Bass line. **Estimated Cost: \$14.8M**

Add a 69kV bus tie CB to Hadley station. **Estimated Cost: \$0.8M**

Total Estimated Transmission Cost: \$15.6M

Alternatives Considered:
 Considering the location of customers served from this line and the connection back to 138 kV sources in the area, no viable cost-effective transmission alternative was identified.

Project Status: Scoping
Project Estimated ISD: 4/3/2023

Legend	
500 kV	
345 kV	
138 kV	
69 kV	
34.5 kV	
23 kV	
New	

Existing

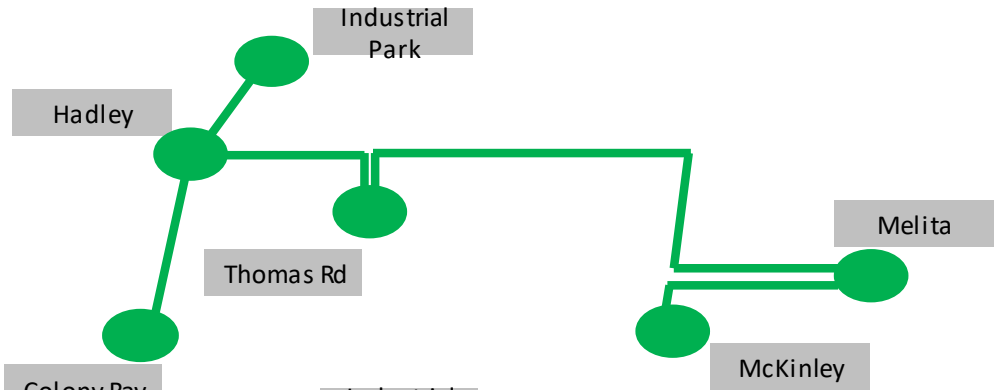

Proposed

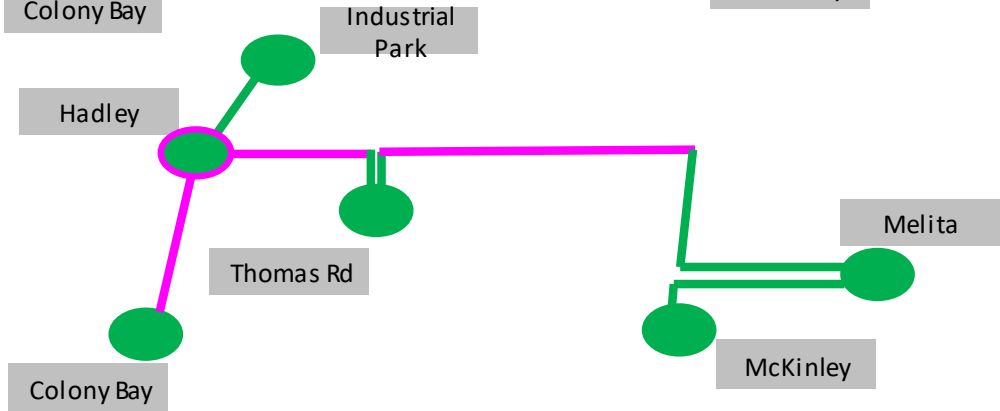

AEP Transmission Zone M-3 Process Main Street-Riverside 34.5kV Line Rebuild

Need Number: AEP-2020-IM002

Process Stage: Solution Meeting 07/17/2020

Previously Presented: 02/21/2020

Supplemental Project Driver: Equipment Condition/Performance/Risk

Specific Assumption Reference: AEP Guidelines for Transmission Owner Identified Needs (AEP Assumptions Slide 8)

Problem Statement:

Main Street-Riverside 34.5kV line:

- 4.1 miles of the 4.6 mile 34.5kV line from Main St. –Riverside 34.5kV:
 - 1930's double circuit steel lattice towers and 1950's wood pole line with cross arm construction
 - 15 structures with at least one open condition (21% of the line)
 - Open conditions include pole leaning, rot, woodpecker or insect damage

Riverside Station:

- There are (2) 34.5kV oil filled breakers of FK-type 1960's vintage
 - Circuit breaker G has exceeded it's manufacturer designed number of fault operations
 - The common failure mode documented by AEP are compressor failures and valve defects which cause low pressure and oil leaks
 - The manufacturer no longer provides support for this fleet of circuit breakers. Spare parts are not available.

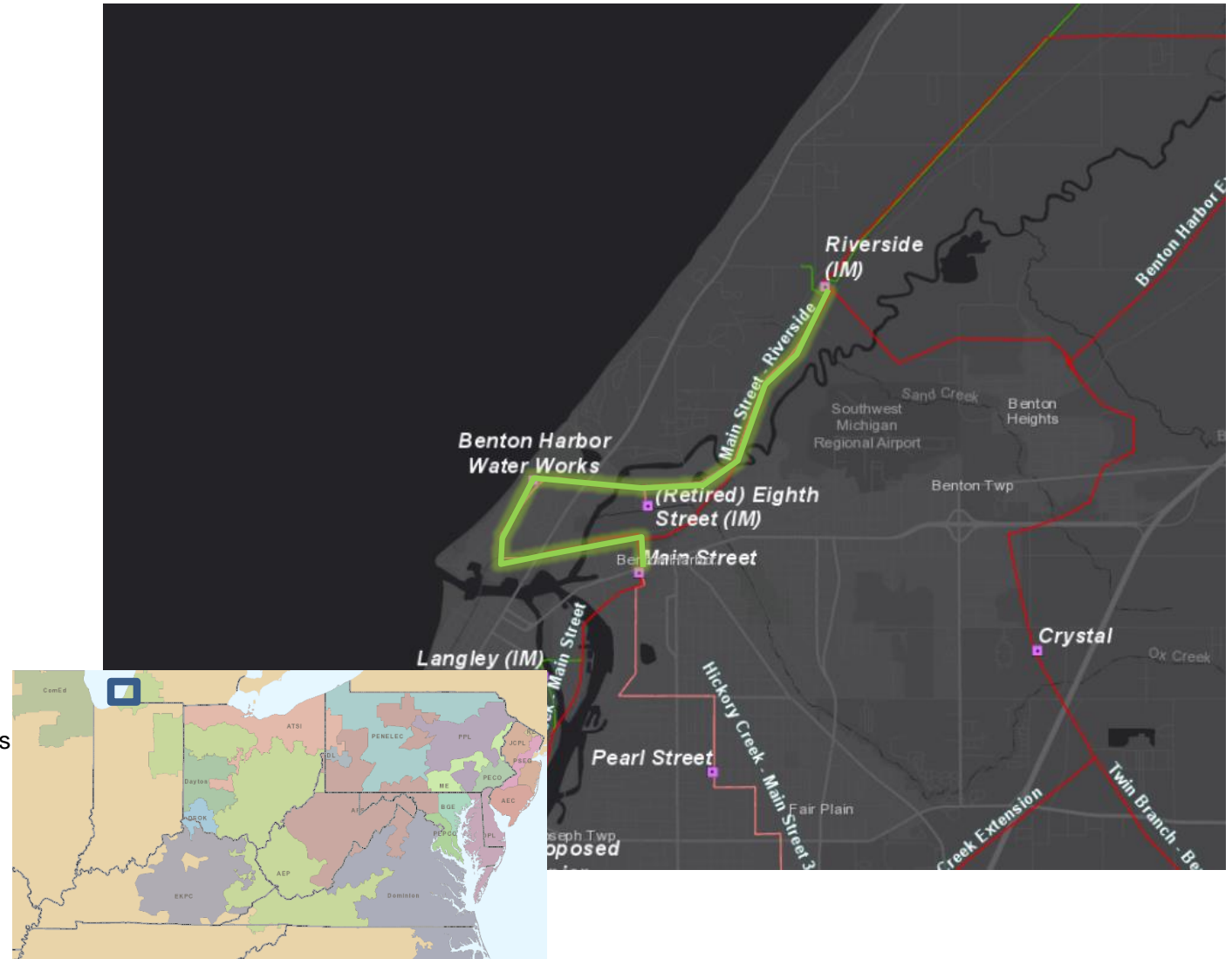

AEP Transmission Zone M-3 Process Main Street-Riverside 34.5kV Line Rebuild

Need Number: AEP-2020-IM013

Process Stage: Needs Meeting 07/17/2020

Previously Presented: 03/19/2020

Supplemental Project Driver: Equipment Condition/Performance/Risk

Specific Assumption Reference: AEP Guidelines for Transmission Owner Identified Needs (AEP Assumptions Slide 8)

Problem Statement:

Riverside Station:

- (2) 138kV Breakers “O” & “A”
 - 1988 vintage SF-6 filled breakers
 - The breaker type has hydraulic leak issues on internal mechanisms which are caused by porous cylinder blocks and chips in the seal groove on the spring connecting rods.
 - Breaker A has operated for a fault 17 times exceeding its manufacturer recommendation of fault operations (10)

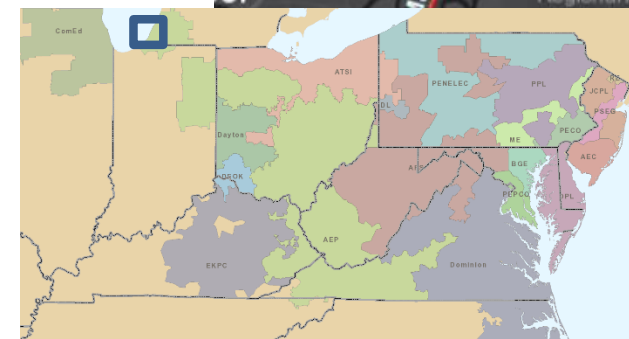
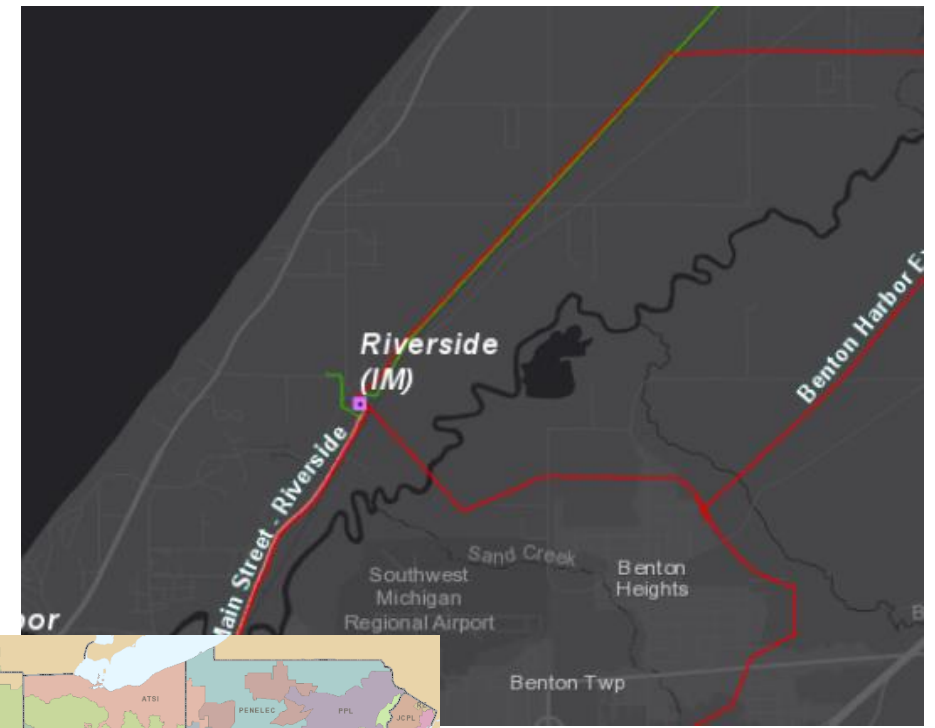

AEP Transmission Zone M-3 Process Main Street-Riverside 34.5kV Line Rebuild

Need Number: AEP-2020-IM002, AEP-2020-IM013

Process Stage: Solution Meeting 07/17/2020

Proposed Solution:

Main St.-Riverside 34.5kV line:

Rebuild on center line approximately 4.1 miles of Main St-Riverside 34.5kV line with DOVE 556.5 ACSR 26/7.

Estimated Cost: \$13.3M

Riverside Station:

Replace (2) 138kV breakers and (2) 34.5kV breakers at Riverside. While at the station and taking advantage of the outage AEP will install a new 34.5kV breaker to bring Whirlpool customer, whose delivery point is currently one tower outside of the station, into Riverside station. Install high side circuit switcher to 138/69-34.5kV transformer.

Estimated Cost: \$3.3M

Total Transmission Estimated Cost: \$16.6M

Alternatives:

Rebuild the line on a new greenfield route. The location of the taps on this line, and the lake immediately west there are no more feasible line routes in this area. To continue service to the customers tapped on this line the line must be rebuilt on the existing route.

Proposed IS Date: 02/14/2024

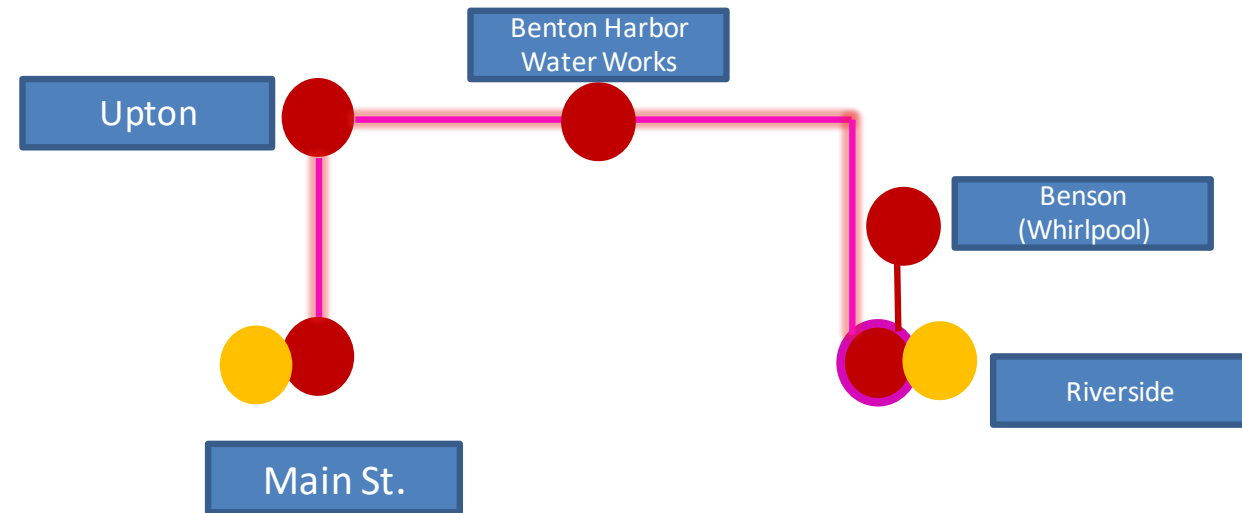

Legend	
500 kV	
345 kV	
138 kV	
69 kV	
34.5 kV	
23 kV	
New	

AEP Transmission Zone M-3 Process Baileysville Station Project

Need Number: AEP-2020-AP007

Process Stage: Solutions Meeting 7/17/2020

Previously Presented: Need Meeting 2/21/2020

Supplemental Project Driver:

Equipment Material/Condition/Performance/Risk

Specific Assumption Reference:

AEP Guidelines for Transmission Owner Identified Needs (AEP Assumptions Slide 8)

Problem Statement:

- Baileysville Station
 - 138 kV circuit breakers G, H, I, K, L and N are SF6 filled type breakers, the only 6 of this specific type on AEP's system
 - Vintage 1980s
 - Limited manufacturer support
 - Obsolete parts that are not available for replacement.
 - 46 kV CSAA is an SF6 filled 2030-69 type circuit switcher
 - Vintage 1990s
 - S&C 2030 circuit switcher has no gas monitor and sister units have a history of malfunctions
 - 138 kV CS CC is an SF6 filled MARK V-138 type circuit switcher.
 - Vintage 1990s
 - This type of switcher have presented AEP with a large amount of failures and mis-operations.
 - Mark V family has no gas monitor
 - Currently 79% of the relays at Baileysville Station are in need of replacement
 - 28 electromechanical and 8 static type relays
 - These type of relays have limitations with regard to fault data collection and retention.
 - Capacitor Bank BB, vintage 1976, has blown fuses and defective cans.
 - The station has seen significant flooding; as recently as 2009 the entire station flooded. In 2001, the control house was flooded with 1.5 feet of water.
 - The station has insufficient room for safe ingress/egress and for accessing equipment around the station.

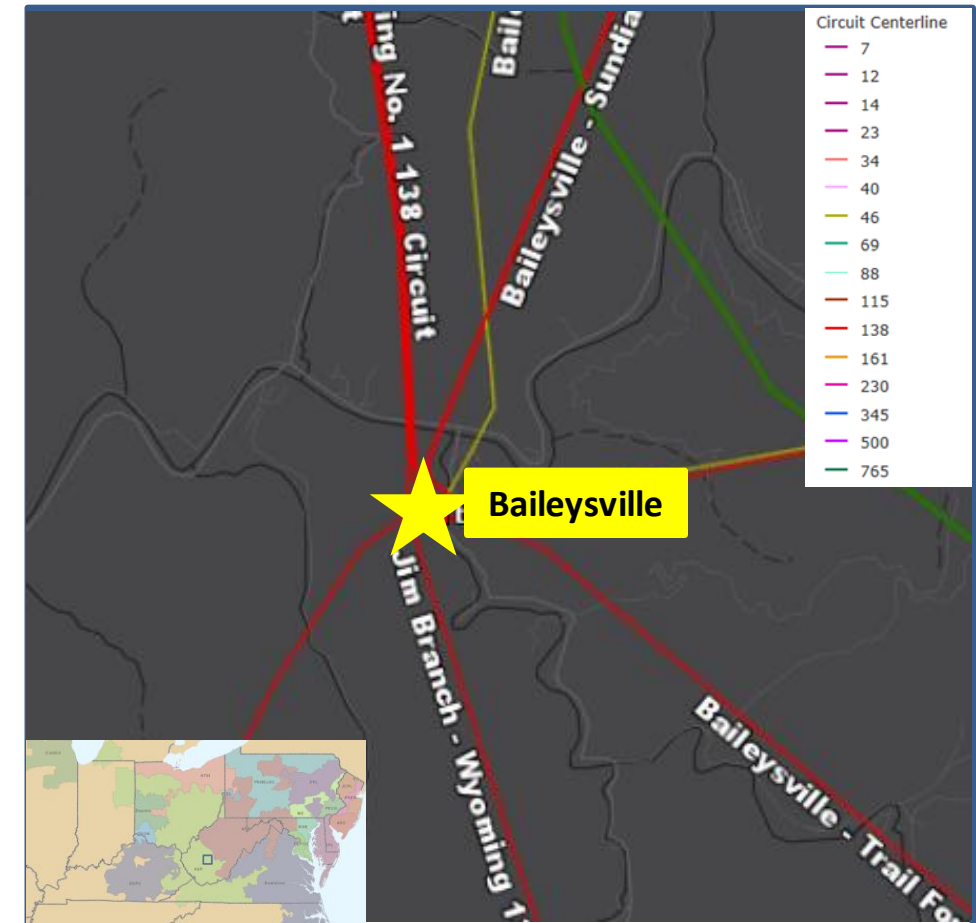

AEP Transmission Zone M-3 Process Baileysville Station Project

Need Number: AEP-2020-AP007

Process Stage: Solutions Meeting 7/17/2020

Proposed Solution:

Replace existing 138 kV CBs G, H, I, K, L and N with six new 138 kV 40 kA circuit breakers. Replace existing 138 kV cap bank BB and install a new 138 kV breaker on the new cap bank. Replace existing 46 kV cap bank switcher with a new cap bank switcher. Install a high side circuit switcher on the existing 138/46 kV transformer. Upgrades will be made to the existing road into the station to improve access and space constraints. A flood wall will be installed to mitigate flooding concerns.

*Note: 138 kV CS CC failed and has been replaced.

Total Estimated Cost: \$10.1M

Alternatives Considered:

Rebuild Baileysville station at a new Greenfield site. Install one new 138/46 kV XFR, nine 138 kV circuit breakers in a breaker and a half configuration, install a new 138 kV cap bank, install two new 46 kV circuit breakers and one new 46 kV cap bank on the new 46 kV bus. The new Greenfield site would require the relocation of six 138 kV lines and two 46 kV lines, approximately one mile to the new site. The additional work/cost to relocate the lines and station would not be prudent. **Estimated Cost: \$53.1M**

Projected In-Service: 7/1/2022

Project Status: Scoping

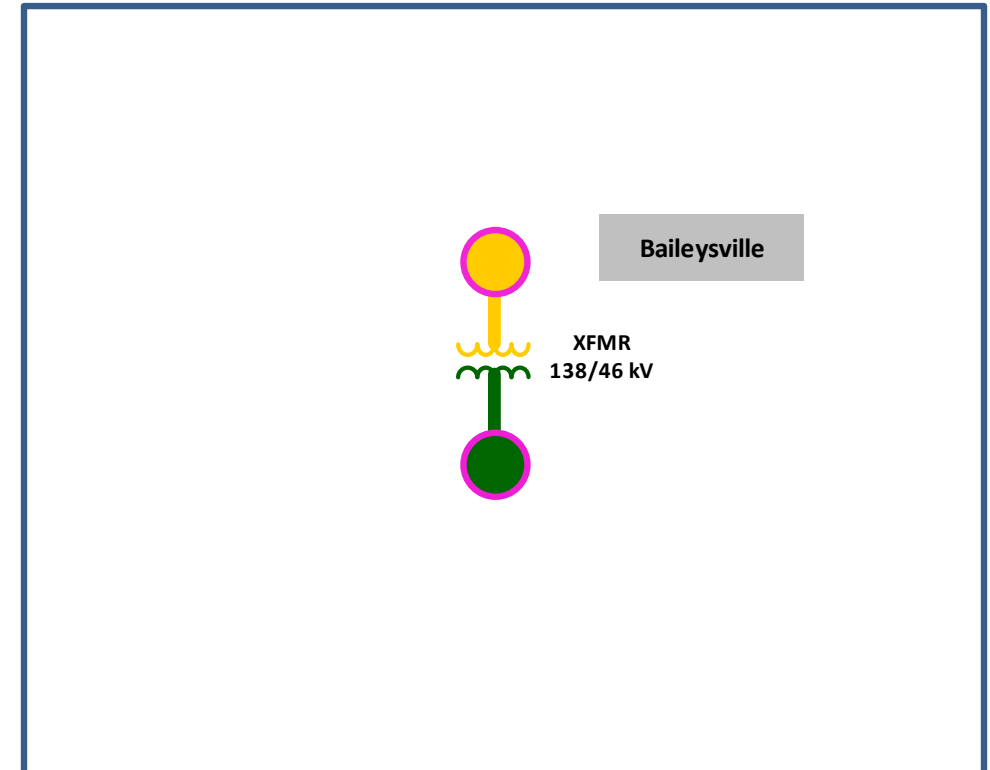

AEP Transmission Zone M-3 Process Mullens Station

Need Number: AEP-2019-AP002

Process Stage: Solutions Meeting 7/17/2020

Previously Presented: Needs Meeting 2/20/2019

Supplemental Project Driver: Equipment Condition/Performance/Risk

Specific Assumption Reference:

AEP Guidelines for Transmission Owner Identified Needs (AEP Assumptions Slide 8)

Problem Statement:

- Transformer Bank #4 138/46 kV
 - Short circuit strength breakdown caused by the amount of high energy electrical through fault events
 - Numerous gases are at the IEEE level 2 condition level with acetylene and ethylene being at the highest condition level 4, which negatively impacts the oil dielectric
 - Major carbonization of the insulating paper as occurred from these numerous through fault events, indicating that this unit is near the end of its useful life
 - There is a bad fan on transformer #4, on the bottom of cooling group 2
- Grounding Bank #3
 - Upward trending of oil moisture content resulting in downward trending to the oil dielectric strength
 - Increasing moisture content is a resultant of water ingress and/or break down of paper insulation of TF windings
 - Short circuit strength breakdown caused by the amount of thermal through fault events
- Existing Gr. SW. MOAB configuration on the 138/46 kV and 138/34.5 kV transformers create faults in the station; known safety hazard in legacy station designs
- 63 of the 74 relays in the station (85% of all station relays) are of the electromechanical type which have significant limitations with regards to fault data collection and retention
- 13.2kV CBs R & S at are oil filled breakers without oil containment

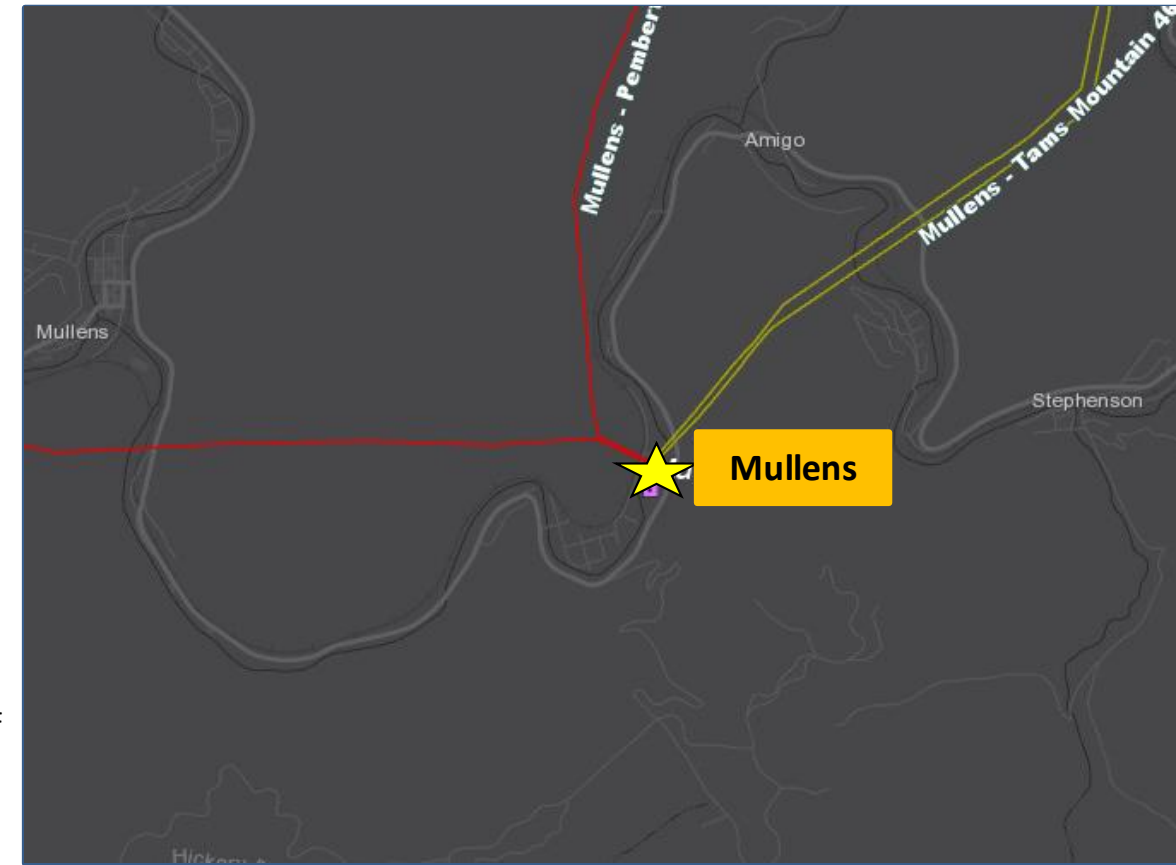

AEP Transmission Zone M-3 Process Mullens Station

Need Number: AEP-2019-AP002

Process Stage: Solutions Meeting 07/17/2020

Proposed Solution:

138/46 kV transformer #4 is being replaced, including a high side circuit breaker, under PJM baseline project B3116.

Replace existing grounding bank with a new grounding bank. Install high side circuit breaker the existing 138/34.5 kV transformer. Install a new 138 kV 3000 A 40 kA circuit breaker towards Wyoming station. Install a new DICM.

Total Estimated Transmission Cost: \$6.7M

Alternatives Considered:

- 1. No viable transmission alternative.

Projected In-Service: 2/17/2022

Project Status: Scoping

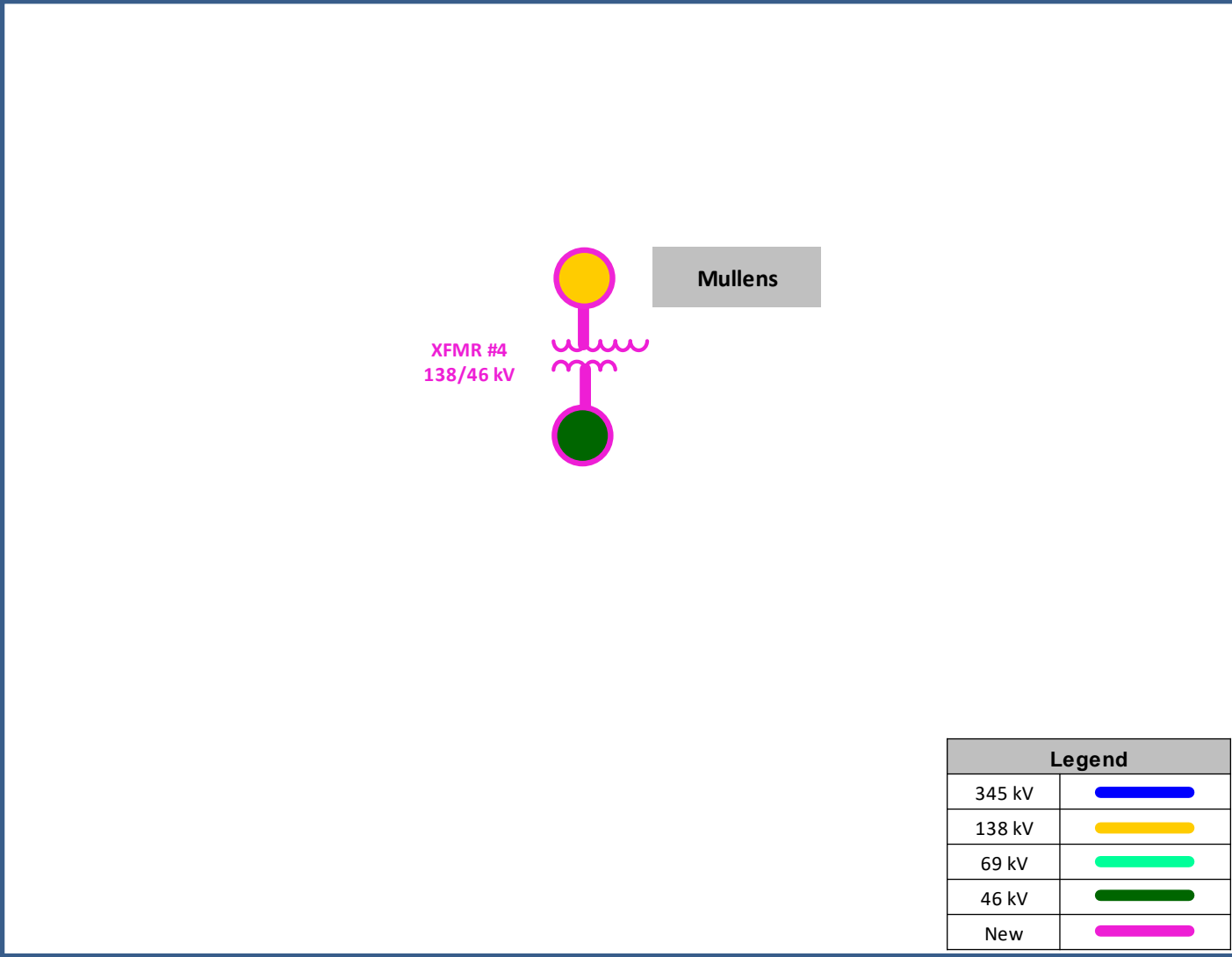

This slide intentionally left blank

This slide intentionally left blank

This slide intentionally left blank

This slide intentionally left blank

AEP Transmission Zone M-3 Process Chemical Area Project

Need Number: AEP-2018-AP018

Process Stage: Solution Meeting 7/17/2020

Previously Presented: Needs Meeting 1/11/2019

Supplemental Project Driver: Equipment Material/Condition/Performance/Risk

Specific Assumptions Reference: AEP Guidelines for Transmission Owner Identified Needs (AEP Assumptions Slide 8)

Problem Statement:

Chemical 138/46 kV XF #1 has been declared a failure. Operations has noted that Chemical 138/46 kV XF #1 fans and cooling system are not working properly and winding temperature was documented at an extremely hot level of 109°C prior to taking the unit offline in 2017. There are no parts attainable to repair the obsolete cooling system. In addition, interfacial tension has been diminished since 2002. This is an early indication of the development of sludge which can impede oil circulation, further hampering the ability of the unit to cool. Based on dissolved gas analysis, the observed gas concentrations, specifically of ethylene and acetylene, are likely the result of a mixture of thermal and electrical faults along with the carbonization of the insulating paper. The signal of insulation paper carbonization, which generates particles in the oil, highly correlates to the generation of sludge indicated by the interfacial tension.

Chemical 138/46 kV XF #2 moisture levels have recently been increasing, resulting in downward trending dielectric strength. In addition, interfacial tension has been on the decline. This is an early indication of the development of sludge which can impede oil circulation and cooling. Operations has noted numerous conditions with this unit, most critical of which is that the bank was derated to 33.75 MVA because only one pump of three is operational for the cooling system. There are no parts attainable to repair the obsolete cooling system.

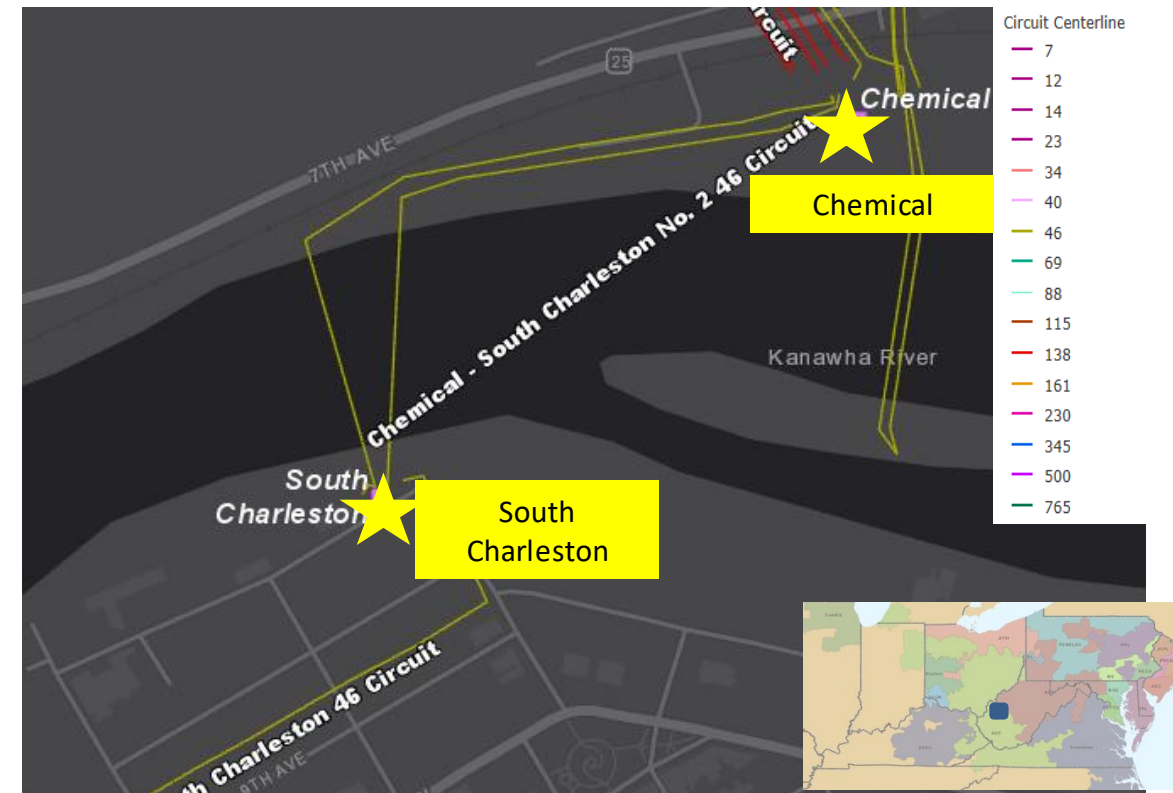

AEP Transmission Zone M-3 Process Chemical Area Project

Need Number: AEP-2018-AP018

Process Stage: Solution Meeting 7/17/2020

Previously Presented: Needs Meeting 1/11/2019

Supplemental Project Driver: Equipment Material/Condition/Performance/Risk

Specific Assumptions Reference: AEP Guidelines for Transmission Owner Identified Needs (AEP Assumptions Slide 8)

Problem Statement:

The 46kV CBs C, G, H, Q, R, and S are oil filled breakers without secondary oil containment. Oil filled breakers have much more maintenance required due to oil handling than their modern, SF6 equivalents do not require. CBs G and H are 2 of 40 in the FK-72.5-27000-10 model family remaining on the AEP system. CB A is the last FK-339-46-1500-Y model on the entire AEP system. CBs B, Q, R, and S are the last 4 in the FK-339-46-1500-5 model family remaining on the entire AEP system. CB C is the last FK-46-1500 model on the entire AEP system. This scarcity of sister units makes finding spare parts for these units difficult to impossible, and these models are no longer vendor supported.

The 46kV CS CC is an S&C2030-69 model. The S&C 2030 circuit switcher model family has no gas monitor and sister units on the AEP System have experienced malfunctions; the major ones include gas loss, interrupter failures, and operating mechanism failures.

Model: 2023 RTEP Model

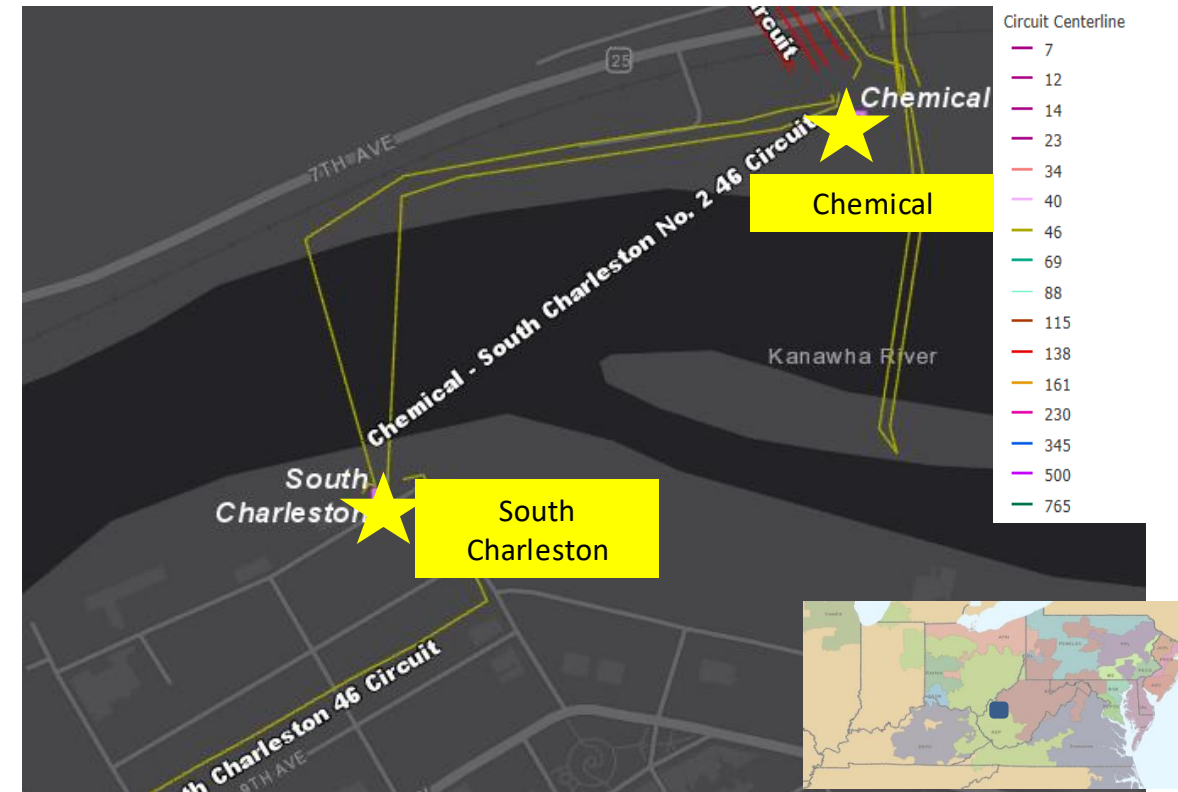

AEP Transmission Zone M-3 Process Chemical Area Project

Need Number: AEP-2019-AP010

Process Stage: Solution Meeting 7/17/2020

Previously Presented: Needs Meeting 4/23/2019

Supplemental Project Driver: Equipment Material/Condition/Performance/Risk

Specific Assumptions Reference: AEP Guidelines for Transmission Owner Identified Needs (AEP Assumptions Slide 8)

Problem Statement:

- South Charleston 46kV CBs A and B are 460G-3000 oil filled breakers.
 - Oil breakers are more difficult to maintain as oil spills have the potential to occur during maintenance which can be an environmental and safety hazard.
 - These are the last 2 circuit breakers in the 460G-3000 CB model family on the AEP system, making spare parts difficult or impossible to obtain.
- Chemical – South Charleston 46 kV #1 (~0.5mi) currently has 9 open conditions on 8/8 structures.
 - The majority of the circuit is constructed with 1950s wood structures and lattice structures.
 - The conditions include rot shell, insect damage and heavy rust.
- Chemical – South Charleston 46 kV #2 (~0.5mi) currently has 16 open conditions on 9/9 structures.
 - The majority of the circuit is constructed with 1950s lattice and wood structures.
 - The conditions include rot and heavy rust and rot shell.

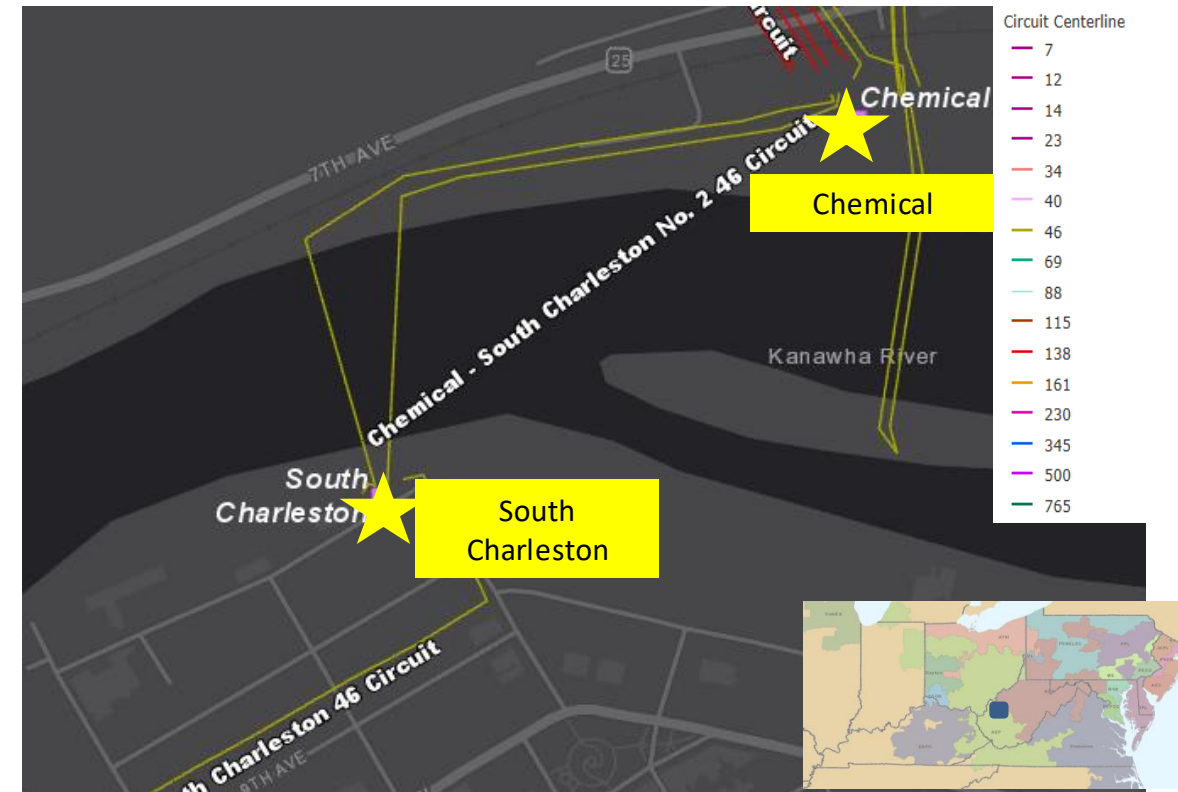

AEP Transmission Zone M-3 Process Chemical Are Project

Need Number: AEP-2018-AP018, AEP-2019-AP010

Process Stage: Solutions Meeting 7/17/2020

Proposed Solution:

At Chemical station, replace existing 138/46 kV 45 MVA transformers #1 and #2 with two new 138/46 kV 90 MVA transformers and install two 138 kV high side circuit switchers on each transformer. Retire 138/46 kV transformer #4. Retire 46 kV 18 MVAR capacitor and switcher “DD”. Retire 46 kV bus #1, bus #2 and bus #3. Rebuild the 46 kV into a fourteen breaker ring configuration. Replace grounding banks #7 and #8. **Estimated Cost: \$16.8M**

Line work is required to accommodate the new station configuration on the Chemical – Turner 138 kV line and Chemical – Chesterfield 46 kV line. **Estimated Cost: \$0.5M**

Remote end work required at Turner Station, Central Avenue Station and Ward Hollow Stations. **Estimated Cost: \$1.6M**

Rebuild the Chemical – South Charleston #1 and Chemical – South Charleston #2 46 kV lines with a new double circuit 46 kV line (69 kV standards) from Chemical – Criel Mound. **Estimated Cost: \$5.4M**

At South Charleston, retire the existing circuit breakers A and B and install four new 46 kV 40 kA circuit breakers in a ring at a new station (Criel Mound) adjacent to the existing South Charleston Station. **Estimated Cost: \$11.0M**

Total Estimated Trans Cost: \$35.3M

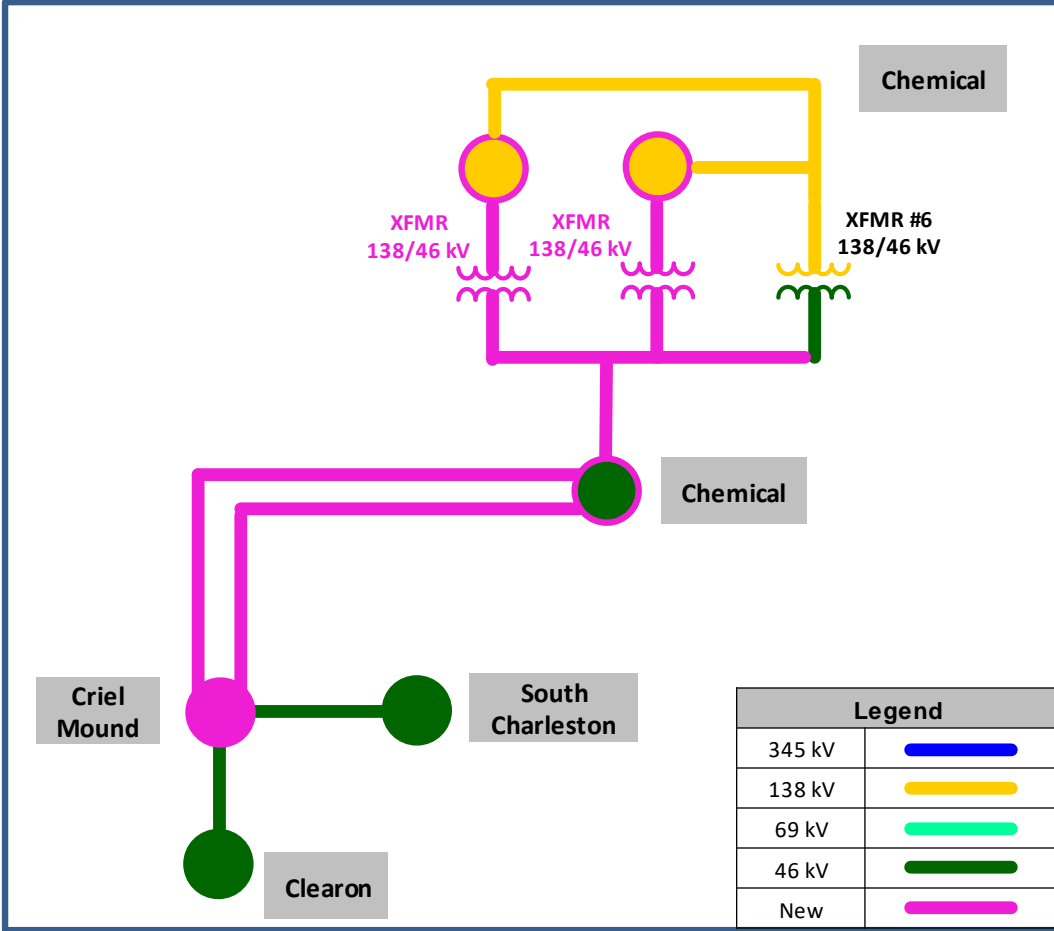

AEP Transmission Zone M-3 Process Chemical Area Project

Ancillary Benefits:

The creation of a 46 kV ring bus improves the Charleston Area reliability by having at least one 138-46 kV transformer in service at all times to the entire 46 kV system supplied from Chemical Station. In the present configuration, with the No. 1 and No. 2 46 kV Buses electrically separated from the No. 3 46 kV Bus, 46 kV circuit overloads and 46 kV low voltages are a constant contingency issue. Tying all of the 46 kV buses together at Chemical Station creates much more reliability to the Charleston Urban stations, including the State Capitol Complex.

Alternatives Considered:

Replacing equipment at Chemical station in place is not preferred due to the significant outage constraints and constructability concerns. A breaker and half configuration was also considered at Chemical Station, however due to space constraints and the amount of site development required to achieve this configuration it was not pursued. Considering the availability of space at the existing station with the inability to expand and the outage time reductions of building in the clear, the ring bus configuration is recommended. **Estimated Cost: \$19.8M**

Rebuilding the existing Chemical – South Charleston #1 and #2 lines into the existing South Charleston along with replacing the existing circuit breakers A and B at the existing station was considered. There are significant space constraints at South Charleston due to the 46 kV transmission line structures being located within the station as well as the 46 kV bus being constructed on the transmission line structures. The station is located within a neighborhood, so space for equipment to construct the new T-Line structures at this location is very limited. Due to customers being served directly out of the existing South Charleston station, the required outage lengths for this work would not be available if constructed in the existing location. It is not physically feasible to perform the necessary work at the existing site.

Projected In-Service: 10/17/2022

Project Status: Scoping

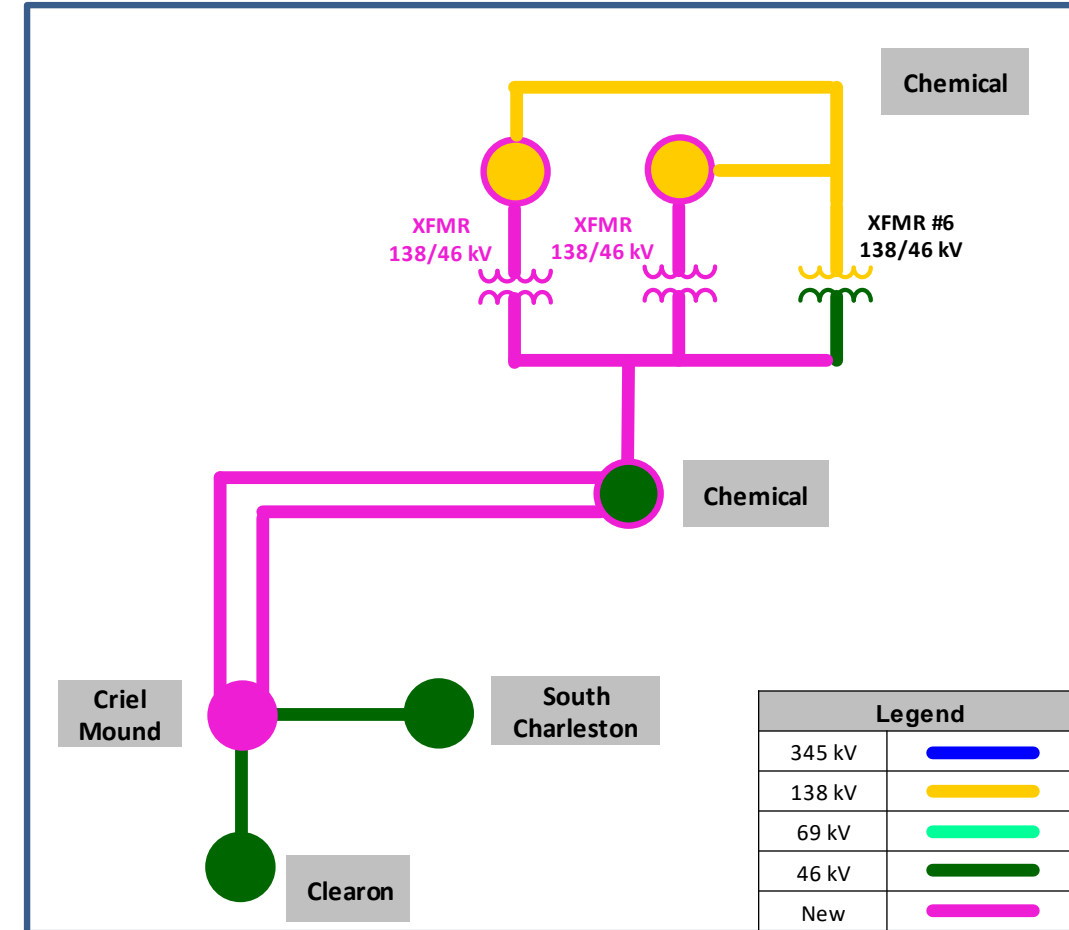

Appendix

High Level M-3 Meeting Schedule

Assumptions	Activity	Timing
	Posting of TO Assumptions Meeting information	20 days before Assumptions Meeting
	Stakeholder comments	10 days after Assumptions Meeting
Needs	Activity	Timing
	TOs and Stakeholders Post Needs Meeting slides	10 days before Needs Meeting
	Stakeholder comments	10 days after Needs Meeting
Solutions	Activity	Timing
	TOs and Stakeholders Post Solutions Meeting slides	10 days before Solutions Meeting
	Stakeholder comments	10 days after Solutions Meeting
Submission of Supplemental Projects & Local Plan	Activity	Timing
	Do No Harm (DNH) analysis for selected solution	Prior to posting selected solution
	Post selected solution(s)	Following completion of DNH analysis
	Stakeholder comments	10 days prior to Local Plan Submission for integration into RTEP
	Local Plan submitted to PJM for integration into RTEP	Following review and consideration of comments received after posting of selected solutions

Revision History

7/7/2020 – V1 – Original version posted to pjm.com

7/15/2020 – V2 – Remove Slides #21-24: AEP-2019-IM014 and AEP-2020-OH008